

NON CANADIAN VEHICLE MARKINGS:

A look at the markings, colour schemes and vehicles of the world's armies.

Part 34: Test Vehicles at the Gunnery School, Lulworth Camp, Dorset

Churchill Mk.VI - 'T173028/B'

Khaki Brown SCC 2

T.173028/B

Vehicle Serial

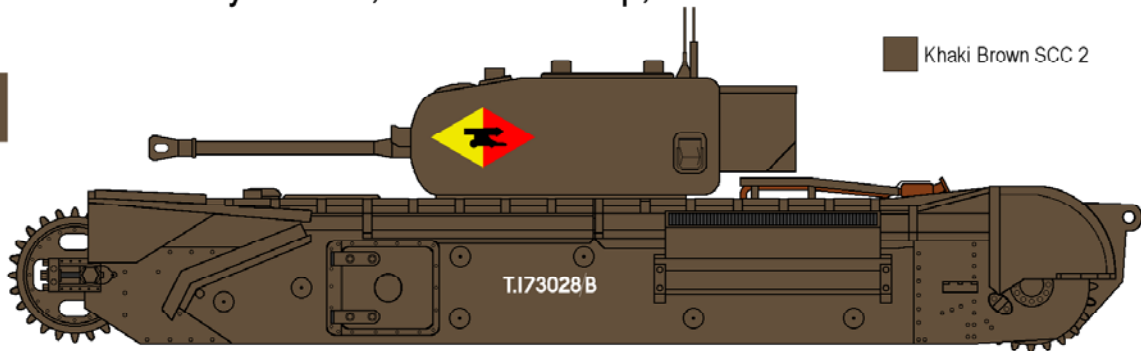
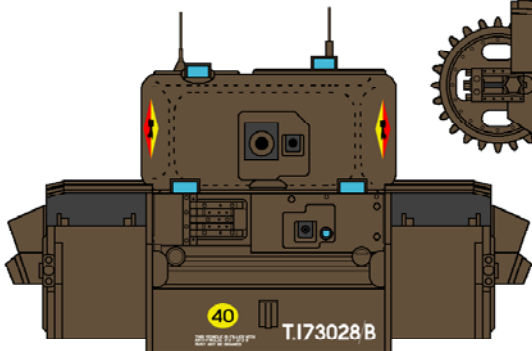

Bridge Class:



40-Tons



Gunnery School Crest

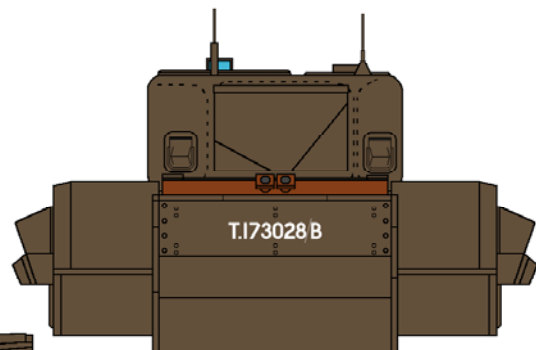

THIS VEHICLE IS FILLED WITH ANTI-FREEZE 1/3 - 2/3 & MUST NOT BE DRAINED

Anti-Freeze Stencil

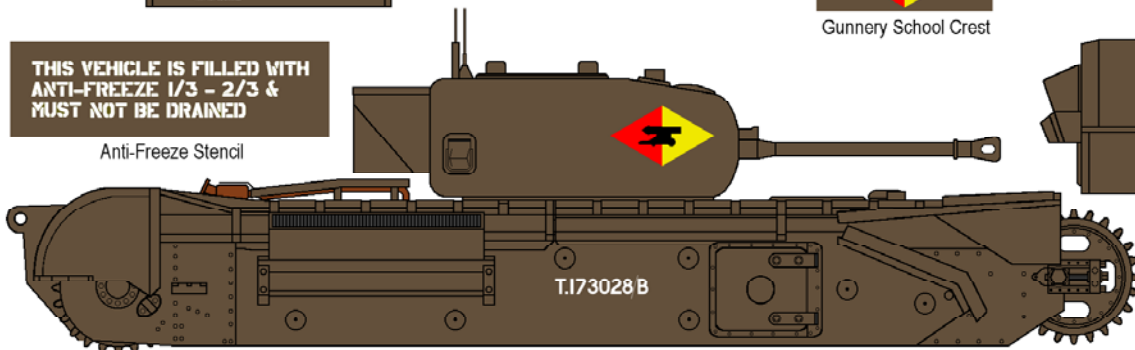

Challenger Mk.I - 'T271904'

There may not be many markings on these vehicles but they are still quite unique.

Bridge Class:



40-Tons

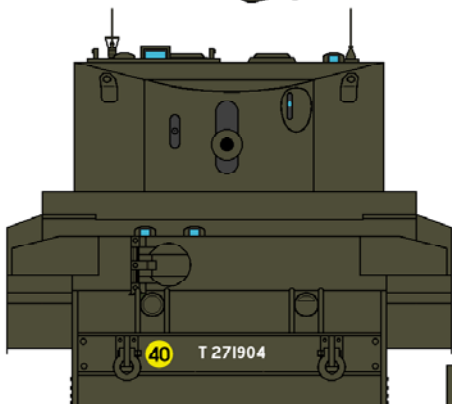
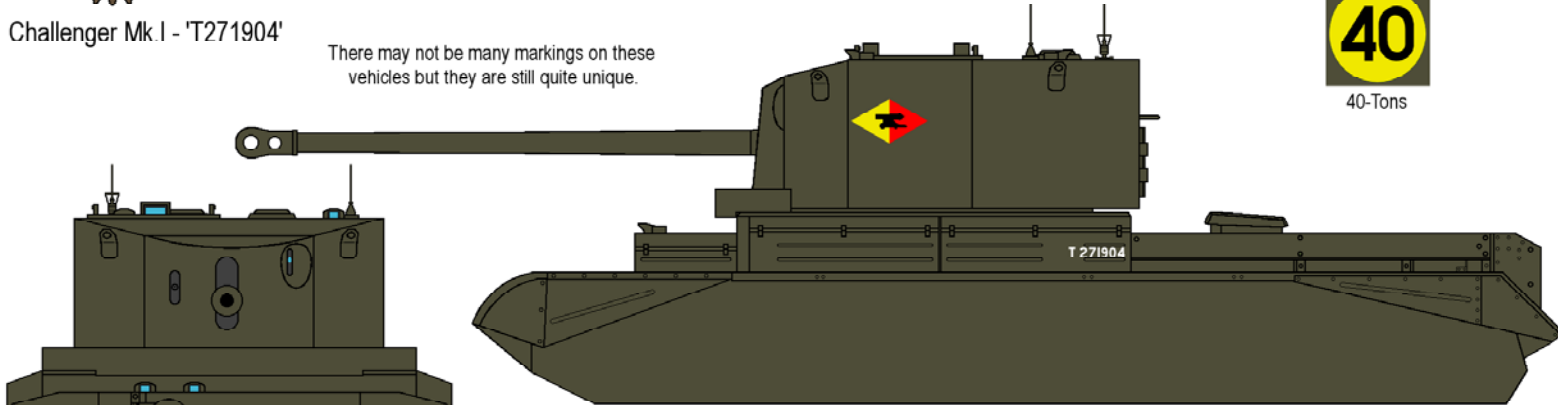

Olive Drab SCC 15

As I cannot tell whether there is a rear serial number to be found on this Challenger, I have left the rear view out. I suspect there was one.

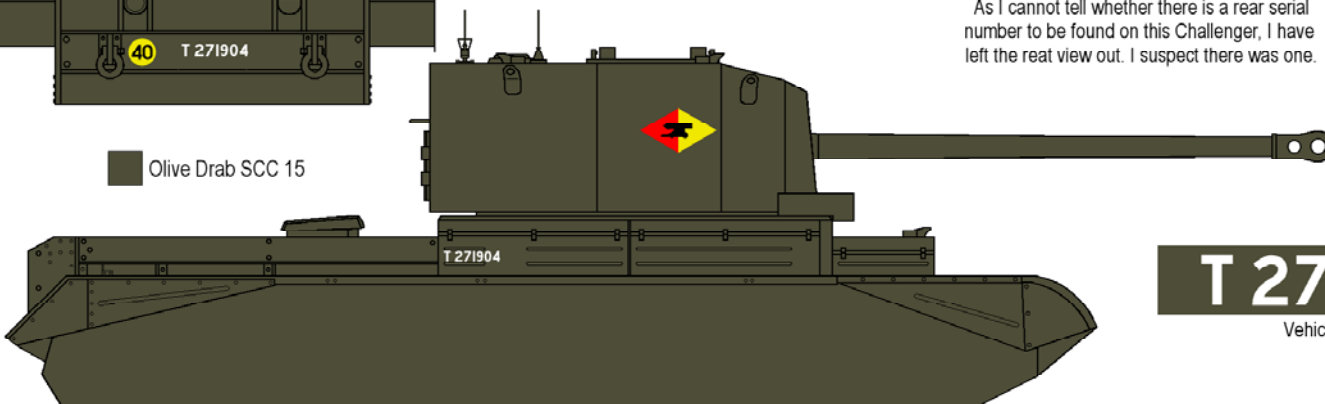

T 271904

Vehicle Serial

NON CANADIAN VEHICLE MARKINGS:

A look at the markings, colour schemes and vehicles of the world's armies.

Part 34: Test Vehicles at the Gunnery School, Lulworth Camp, Dorset

Sherman Mk.IB - 'T269338'

Bridge Class:

30

30-Tons

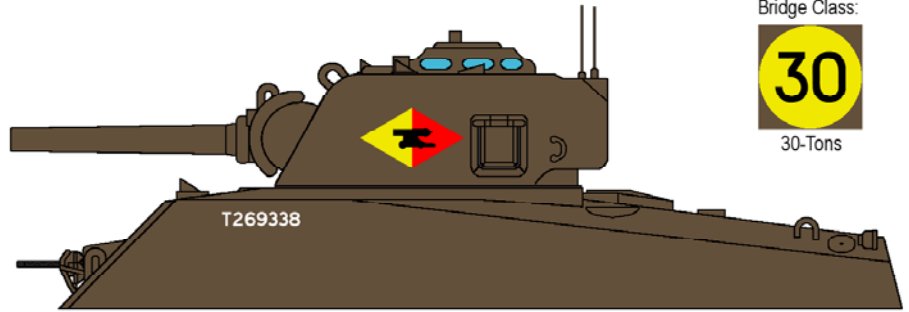
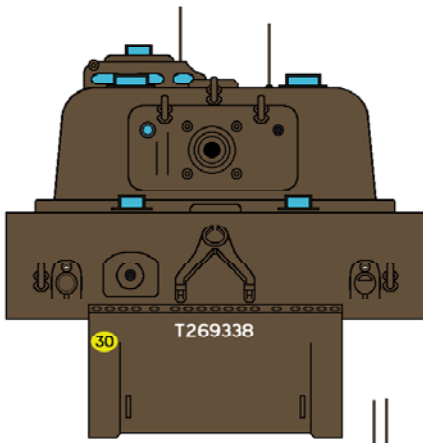

T269338

Vehicle Serial

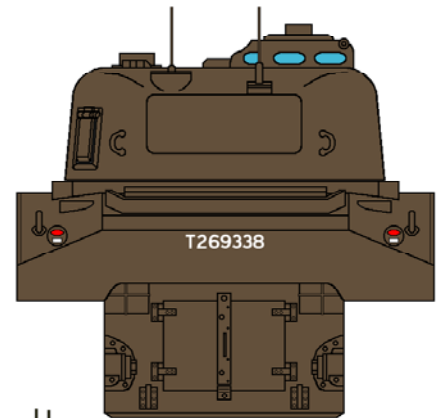

■ Khaki Brown SCC 2

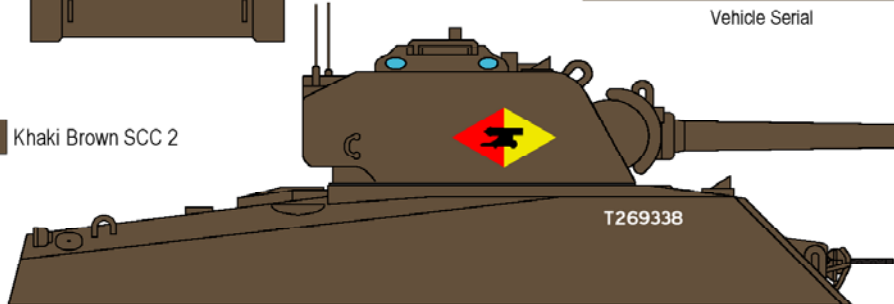

Sherman Mk.VC - 'T148471'

■ Middle Bronze Green No.23 (G3)

T148471

Vehicle Serial
(hull sides)

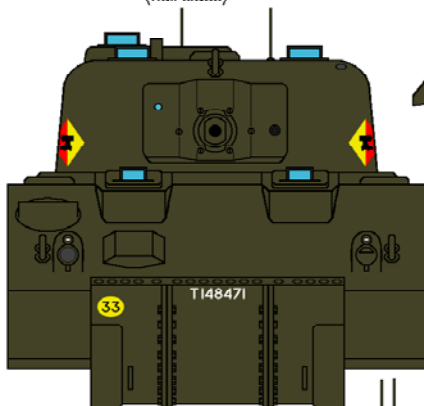

Gunnery School Crest

Bridge Class:

33

33-Tons

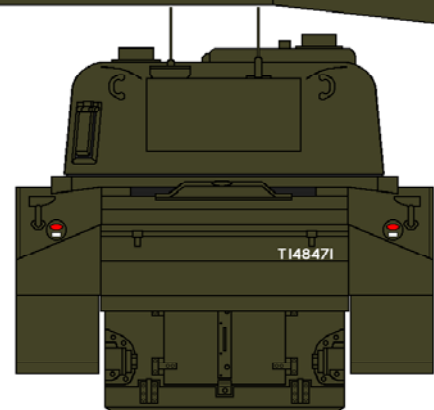
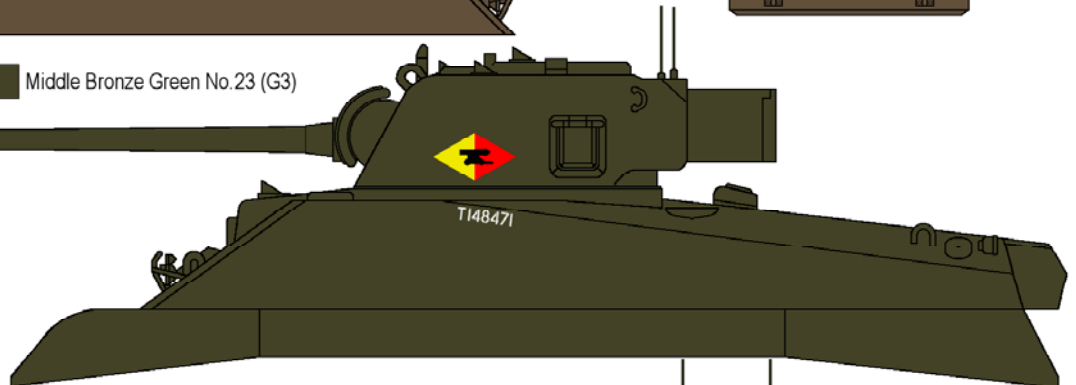

T148471

Vehicle Serial
(front hull & rear box)

